

Choose a Digitally-Controlled Potentiometer Instead of a DAC?

There are two options for designers wishing to translate digital information into its analog corollary—a DCP or a DAC.

Traditional wisdom chooses a DAC when resolution or temperature stability is the reigning concern. That same wisdom selects a DCP when cost, memory, or flexibility with references is needed. Neither the DAC or DCP suppliers were content with small pieces of the market. DAC suppliers countered with smaller packages and smaller prices. DCP manufacturers capitalized on improvements in process technology to provide comparable temperature performance. As both camps jockey for your business, let's take a look at the state of the art.

Table 1 offers a side-by-side comparison of available attributes of DCPs and DACs. A few attributes such as package type are omitted because the two are so similar.

The prominent difference in Table 1 is in component resolution. Most DACs provide fixed resolutions; you can purchase 8-bit, 10-bit, 12-bit... up to 20-bit versions. That means the output voltage spans between the supply voltages (or close) in 256, 1024, or 2ⁿ bit steps. DCPs, on the other hand, are currently limited to 1024 taps (or 10 bits) by process steps that dictate the size of transistor switches and matched resistor structures. The hidden benefit, though, is the freedom to set the voltage on the ends of the potentiometer. If the ends are set at the rails, then the resolution of the output is equal to the number of taps. However, if the ends are set to a span of half the supply, then the output resolution also benefits by that same factor of two. In this way, the resolution of the DCP can be improved for a given application by simply adding resistance in series. The DCP won't feasibly reach 24 bits like some DACs, but the flexibility to vary the voltage across the fixed resistance provides different benefits.

There are many aspects to the flexibility of a DCP. Since the DCP doesn't need to be tied to fixed voltages, it can be easily used in the feedback path of an amplifier. Some DCPs, like the X9C103, incorporate charge pumps so that the output can

swing between dual supplies while the input remains between a single supply and ground. Others, like the AD5280, are designed to operate on a single +15 volt supply or ±5 volts.

Another issue is memory. Often, we would like the system to store information. The traditional solution for both a DAC and DCP is to include a separate EEPROM IC, so critical information would not be lost in case of a power disruption or failure. Most DACs do not include memory. The DCPs that have no integrated memory are labelled as "volatile". Many DCPs now include non-volatile memory. With a minimum amount of EEPROM cells, basic information like wiper position can be stored. If additional EEPROM memory is included within the DCP package, then identification, calibration information, test conditions and more can be stored.

As for temperature stability, first glance gives preference to the DAC, with 5ppm/°C appearing 10 times better than a typical DCP. While it is true that the full-scale resistance of a DCP used to exhibit 600ppm/°C, the recent generations of process technologies provide 50ppm/°C of change in the total end-to-end resistance of a DCP. However, very few DCPs are used in this manner. More commonly, they are used as a voltage divider. When the resistances are relative (as in a voltage divider), it is the relative differences versus temperature that become most important. In this manner, the temperature performance is nearly 4ppm/°C and no longer a performance limitation in DCPs. In regard to DAC temperature performance, be careful when reading the datasheet. Many DACs choose to report a simple, small number like 5ppm/°C as the gain error only. There are many other aspects that will contribute to overall performance versus temperature. A few of these are integral non-linearity, reference tempco and long-term stability on top of the DAC's gain error. High accuracy designs can corral the overall temperature coefficient to about 20ppm/°C, while low-cost versions can easily exceed 100ppm/°C.

TABLE 1. COMPARISON OF DCP AND DAC OPTIONS

TYPICAL PARAMETERS	DCP	DAC
Maximum Resolution	1024 taps (10-bit) within variable max/min	24-bit, fixed
Full-Scale Voltage	Supplies or Variable	Supplies/V _{REF}
Memory	Volatile and non-volatile available, up to 16k additional memory	None
Reported Temperature Stability	± 50ppm/°C full scale, ±4ppm/°C relative match	± 5ppm/°C typical (Gain Error)
Steps	Linear or Logarithmic	Linear
Output Drive	Resistive or Current - Some have output buffer to allow for current drive	Voltage or Current - Includes output buffer to drive low load impedance
Control Interface	Serial SPI, I ² C, up/down, push-button	Serial or parallel I ² C, SPI, QSPI, MICROWIRE, etc.

Application Note 1693

The final three aspects in Table 1 highlight more similarities between the DAC and DCP rather than the differences. Truly, both provide linear output steps. The DCP can also be chosen with logarithmic steps, making it the perfect selection for audio systems. The outputs of either the DAC or DCP can be found with an output buffer to drive small impedance loads, but it is more common to find a DCP in its “natural form” with a simple resistance at the output. The control interface can take a variety of forms. The DAC can offer parallel or serial input while the DCP can offer up/down or push-button controls. Both readily include SPI or I²C interfaces. Although straightforward, these options help govern the best choice for your application.

An example application will best illuminate the benefits of using a DCP. In base station applications (Figure 1), a DCP (ISL22343) is used as a voltage divider to adjust the gate bias on the power transmitter. It sets the amplifier bias current through the buffer and low-pass filter to optimize transmit range. The gate bias is very sensitive—if it's too small, the transmit range is sacrificed and if it's too large, distortion occurs. Setting the initial gate bias is accomplished with a voltage reference. Preserving gate bias is even more difficult in the presence of the large temperature gradients caused by heating of the output transistors. Therefore, the optimum value of gate bias is a function of multiple parameters. A DCP can store its own calibration information, directly set the gate bias for proper function, and dynamically make adjustments to incorporate information from alternate sources like temperature sensors. DACs are more precise, but have yet to incorporate so many different functions.

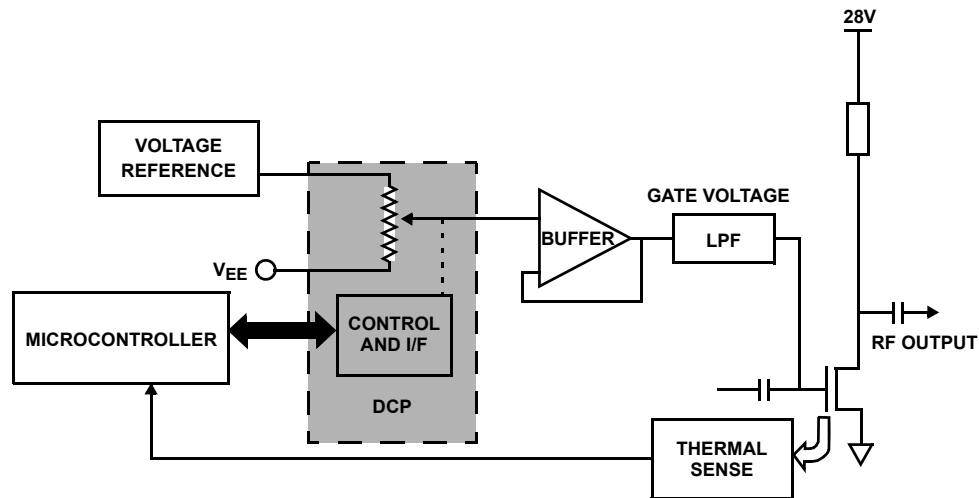

FIGURE 1. BLOCK DIAGRAM OF BASE STATION APPLICATION USING A DCP FOR THERMAL STABILITY

Intersil Corporation reserves the right to make changes in circuit design, software and/or specifications at any time without notice. Accordingly, the reader is cautioned to verify that the Application Note or Technical Brief is current before proceeding.

For information regarding Intersil Corporation and its products, see www.intersil.com